

IT IS THE RESPONSIBILITY OF THE USER ORGANISATION TO PROVIDE THE IDENTITY CARD AND TO FILL IN THE DETAILS REQUIRED.  
 THE IDENTITY CARD SHOULD BE FILLED IN BEFORE THE FIRST USE BY A COMPETENT PERSON, RESPONSIBLE IN THE USER ORGANIZATION FOR PROTECTIVE EQUIPMENT.  
 ANY INFORMATION ABOUT THE EQUIPMENT LIKE PERIODIC INSPECTIONS, REPAIRS, REASONS OF EQUIPMENT'S WITHDRAWN FROM USE SHALL BE NOTED INTO THE IDENTITY CARD BY A COMPETENT PERSON.  
 THE IDENTITY CARD SHOULD BE STORED DURING A WHOLE PERIOD OF EQUIPMENT UTILIZATION.  
 DO NOT USE THE EQUIPMENT WITHOUT THE IDENTITY CARD.  
 ALL RECORDS IN THE IDENTITY CARD CAN BE FILLED IN ONLY BY A COMPETENT PERSON.

# IDENTITY CARD

MODEL AND TYPE OF EQUIPMENT	
-----------------------------	--

REF. NUMBER	
-------------	--

SERIAL NUMBER		DATE OF MANUF.	
---------------	--	----------------	--

USER NAME	
-----------	--

DATE OF PURCHASE		DATE OF PUTTING INTO OPERATION	
------------------	--	--------------------------------	--

## PERIODIC EXAMINATION AND REPAIR HISTORY

	DATE	REASON FOR ENTRY PERIODIC EXAMINATION OR REPAIR	DEFECTS NOTED, REPAIRS CARRIED OUT AND OTHER RELEVANT INFORMATIONS	NAME AND SIGNATURE OF COMPETENT PERSON	PERIODIC EXAMINATION NEXT DUE DATE
1					
2					
3					
4					

EC type examination carried out by INSPEC UK - No. 0194  
 EC type examination carried out by CETE APAVE SUDEUROPE, BP 193, 13322 Marseille, France - 0082

SafetyLiftinGear.com  
 Unit R1D Rockingham Gate Poplar Way  
 West Cabot Park Bristol BS11 0YW Tel:  
 0808 123 69 69 Fax: 0117 9381 602  
 sales@safetyliftinggear.com

# Instruction Manual

EN 795 Class B

CE 0082 Ref.: AT 061

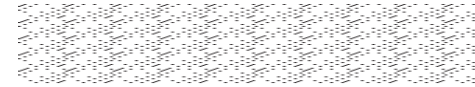

## ANCHOR BEAM

The anchor beam is designed as a portable anchor point. The anchor beam has been tested in according to EN 795 class B as a transportable temporary anchorage. The anchor beam has to be used in conjunction with fall arrest equipment. The anchor beam has to be installed inside the door or window opening of width from 300 to 1280mm. The anchor beam could be the protection for only one person.

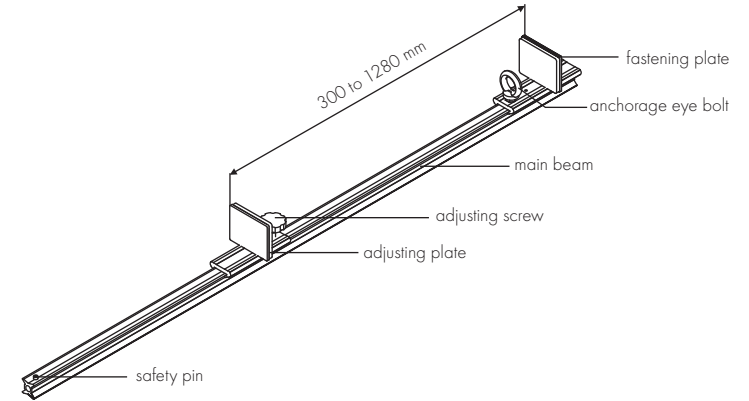

**INSTALLATION** - The anchor beam must be fixed into the stable door or window opening of construction of static resistance unless 10 kN. The anchor beam must be situated horizontally on the ground. It is strictly forbidden to instal the beam in vertical direction.

1. Place the anchor beam inside the opening on the ground. The beam must be placed outside of the area (room) which we are going to work and the anchorage eye bolts should be directed to the workers (fig. 1).

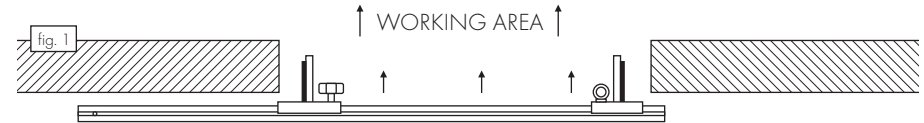

2. Make sure the anchor beam is situated horizontally and fit close to the wall. Push the fastening plate to one side of the opening (fig. 2).



3. Shift the adjusting plate close to the other side of the opening. Tighten it with the adjusting screw to stabilize the beam inside the opening (fig.3). Ensure that the fastening and adjusting plates fit close to the surfaces of the opening. The shape and construction of the opening shall not allowed to the self-existent disconnection of the beam.



## CONNECTING THE FALL ARREST SYSTEM (fig. 4).

1. The worker must be equipped with safety harness complied with EN 361.
2. Fall arrest system must be connected to the anchorage eye bolt of the anchor beam with certified snap hook complied with EN 362.
3. Fall arrest system must be connected to the back or front attaching point of the safety harness. It is strictly forbidden to connect fall arrest system to the side buckles of work positioning belt.
5. To avoid a danger of collision of falling worker with any object or a ground there must be a free clearance below the working level. The minimal distance of the free clearance must be conformable with instructions of fall arrest system which is currently used.
4. The working rope should be tensioned during the work to eliminate the slack of it and to reduce the distance of a free fall.

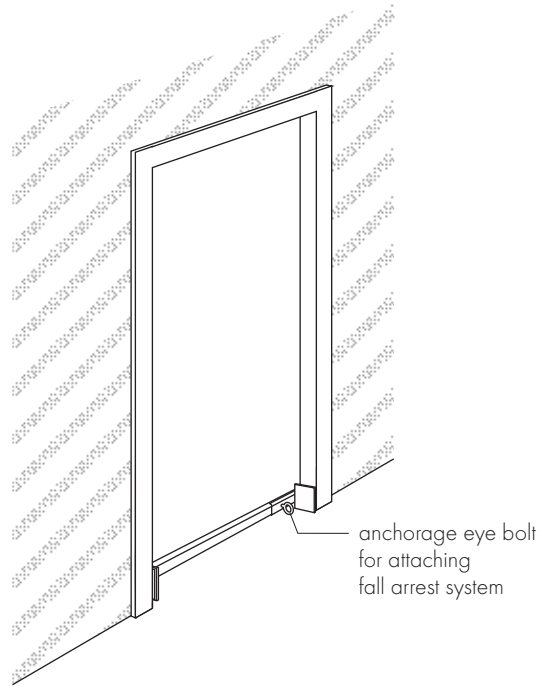
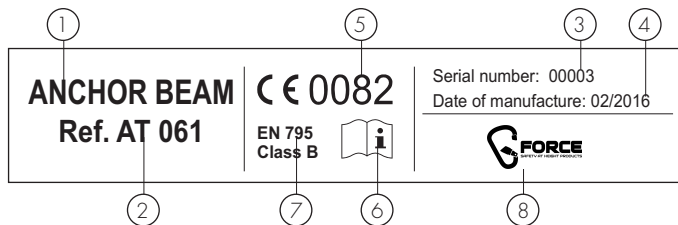

fig. 4

## CONTENT OF THE IDENTITY LABEL

1. type of the device
2. reference number of the device
3. number of the manufacturing series
4. month/year of the device manufacture
5. CE marking and number of a notified body controlling manufacturing of the equipment (art. 11)
6. caution: read the manual
7. European standard
8. name of the manufacturer or distributor



## BASIC RULES OF USING THE ANCHOR BEAM

- the anchor beam can be used only by a trained worker.
- the anchor beam can be the protection for one person only.
- before use the fall arrest system contained the anchor beam, the rescue operation must be introduced to avoid any danger that can happen during use of the equipment.
- before the first use the identity card of the anchor beam must be filled in by a person responsible in company for the fall arrest equipment and kept during whole period of the beam use.
- before each use, a close visual examination of the anchor beam must be carried out in respect of wear, corrosion or any damage that could impair proper performance. There is necessity to check the proper fastening of the anchor beam inside the door opening. Ensure that the anchor beam is situated horizontally on the ground outside the working area and the fastening plates are completely tightened to protect the beam against accidental disconnection. Check the tightening of eye bolts nuts. The examination must be carried out by a person who is going to use the anchor beam. In case of any defect or doubt of correct condition of the anchor beam, do not use it.
- periodical check the connection and adjusting between all elements in your protective equipment to avoid the accidental loosening or disconnection of the equipment.
- annual inspection of the anchor beam must be carried out by a person responsible in company for the safety equipment.  
Whole parts of the anchor beam: beam, fastening plates, eye bolts, side plates, must be controlled in respect of mechanical, chemical and thermal defects. The result of inspection must be recorded in Identity Card.
- there is no limit of usage time but after first five years of using the anchor beam must be made a subject to a fabric control.  
The fabric control can be made by:
  - manufacturer
  - or person recommended by manufacturer
  - or company recommended by manufacturer.During fabric control will be established time of usage till next fabric control
- after arresting a fall the anchor beam must be taken out of service to make a fabric control. The anchor beam must be taken out of service when any defects appear during the everyday inspection. Out of service can be carried out by a person responsible for safety equipment in the company.
- during use the anchor beam must be protected from a contact of acids, solvents, basics or any caustic liquids, open fire and hot metal drops.
- using the anchor beam in connection with fall arrest system must be compatible with manual instructions of the fall arrest systems and obligatory standards:
  - EN 361- for safety harness.
  - EN 362 - for connectors.
  - EN 354, EN 355, EN 360, EN 353-2 - for fall arrest equipment.
  - EN 795 - for anchorages.
- the anchor beam must be stored in a dry place, ventilated, in room temperature and free of sun. Before the first use the device should be stored in manufacturer package.
- the anchor beam must be transported in a package to protect it from a mechanical or chemical damages. Avoid any corrosive, overheated or moisture mechanical and chemical or others defects.
- clean the anchor beam with wet cotton textile. Do not use any acid or basic solvents. After cleaning the device must dry in natural conditions away from any fire and heat. For conservation the beam can be slightly lubricated.
- it is strictly forbidden to make any modifications or repairs to the anchor beam yourself.